

MDT 300-46 (MILL DUTY THRUSTER BRAKES)



INTRODUCTION

Thruster Brake is a device to retard the speed of moving machinery and to stop it accurately to the desired position. The breaking force is applied to the brake shoes by a pre-stressed compression spring. The shoes press on the rotating brake drum retarding its speed, and finally stopping it.

TECHNICAL DATA

ITEM	BRAKE	THRUSTER
MODEL	MDT - 300-46	ST-545
DRUM DIA	300 mm
BRAKE SHOE	Asbestos free/BA
BRAKING TORQUE	72 Kg-m
THRUST	46 Kg
STROKE	50 mm
OIL + CAPACITY	Transformer Oil 3 Litrs
RATED VOLTAGE	415V±10%,3PhAC,50Hz
CURRENT AT 415 V AC	0.6 Amps
POWER	180 Watt
INSULATION	F Class
INGRESS PROTECTION	IP-55 IS/IEC 60529(2001)
SURFACE TEMPERATURE	+50°C
WEIGHT	35 kg	16 kg
POWDER COATING	Colour RAL 7021
OPTION		
LAF	Asbestos Free Liner
LWI	Lining Wear Indicator
OL	Open Brake Limit Switch
MS	Manual Opening & Locking System

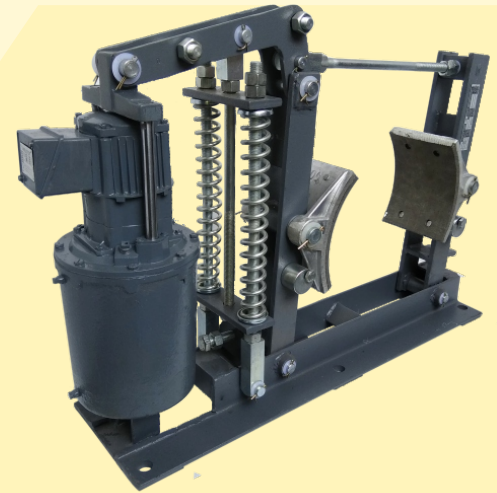

SELECTION OF BRAKE SIZE

Electo-hydraulic thruster is a device which develops linear thrust (or force) required to operate the required mechanism. The input to the device is three phase supply.

The brake torque must be = > than motor full load as referred with drum. Formula as below:

$$T = \text{Torque in Kgm} = \frac{716 \times \text{Hp}}{\text{rpm}}$$

$$T = \text{Torque in Nm} = \frac{9552 \times \text{Kw}}{\text{rpm}}$$

Where Hp/Kw = motor output & rpm = Rev/minute

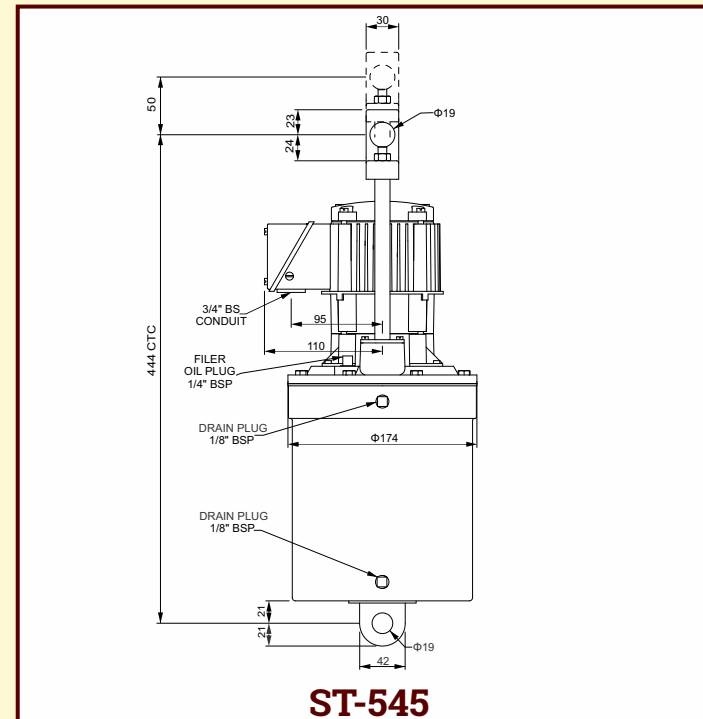
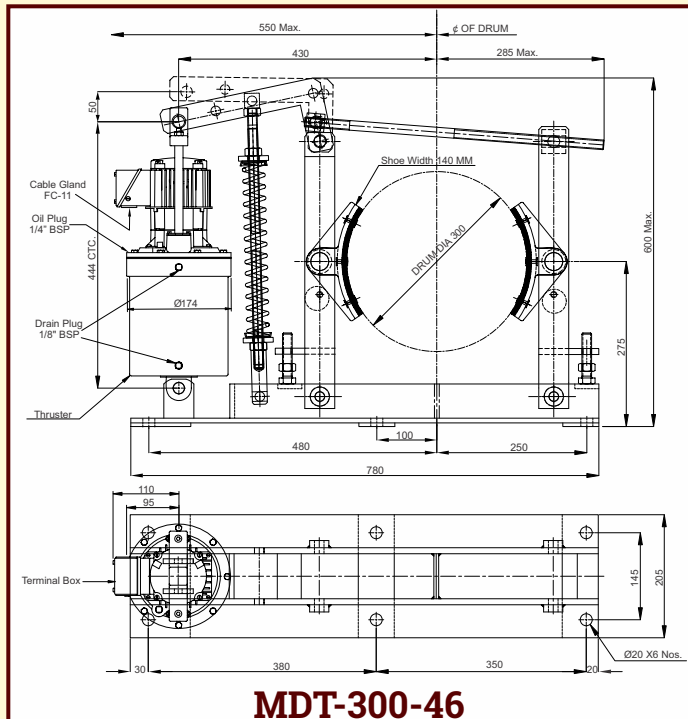

H. O. Unit - I : C-15/16, Nand Jyot Industrial Estate, Andheri-Kurla Road, Mumbai - 400072,
Tel : (022) 42469700/730
E-mail : sales@socgroup.in

Unit - II : Plot No. 4912, G. I. D. C., Phase IV, Vatva, Ahmedabad - 382445
Tel.: (079) 68169700/702/712
E-mail : enquiry2@socgroup.in

Visit us at :
www.speedcontrols.com
www.socremote.com

SPEED-O-CONTROLS PVT. LTD.
CRANE CONTROL GEAR