

THRUSTER BRAKE ELDY SMD (500-121/06)



TECHNICAL DATA

| ITEM | BRAKE | THRUSTER |
|---------------------------------------|---|---|
| MODEL | SMD 500-121/06 | ELD - 121/06 |
| DRUM DIA | 500 mm | ----- |
| BRAKE SHOE FRICTION COEFFICIENT | Asbestos free Without Rivet / BA | ----- |
| BRAKING TORQUE | 350 - 3400 Nm | ----- |
| THRUST | ----- | 121 Kg |
| STROKE | ----- | 60 mm |
| OIL + CAPACITY | ----- | Transformer Oil IS-335 (9.8 Liters)Max |
| RATED VOLTAGE | ----- | 415 V ± 10% 50 Hz 3Ph AC |
| CURRENT AT 415 V AC INRUSH CURRENT | ----- | 1.5 Amps 7.5 Amps.(Inrush) |
| INSULATION | ----- | F Class |
| INGRESS PROTECTION | ----- | IP - 65 IS/IEC 60529 (2001) |
| AMBIENT TEMPERATURE | ----- | 50° C |
| POWER | ----- | 410 Watt |
| WEIGHT | 137 Kg | 33 Kg |
| PAINTING | Hammertone Gray Paint | |
| LAF | Asbestos Free Liner | |
| OPTIONAL FEATURES | | |
| SCD | Aluminum Brake Shoe as per DIN - 15435 | |
| LWA | Lining Wear Adjuster | |
| LWI | Lining Wear Indicator Limit Switch | |
| SS | AISA 420 Hardened & Tampered Stainless Steel Pins | |
| PN | Lubricators on Pins | |
| OL | Open Brake Limit Switch | |
| MS | Manual Opening & Locking System | |

* Non-Standard voltages available on enquiry

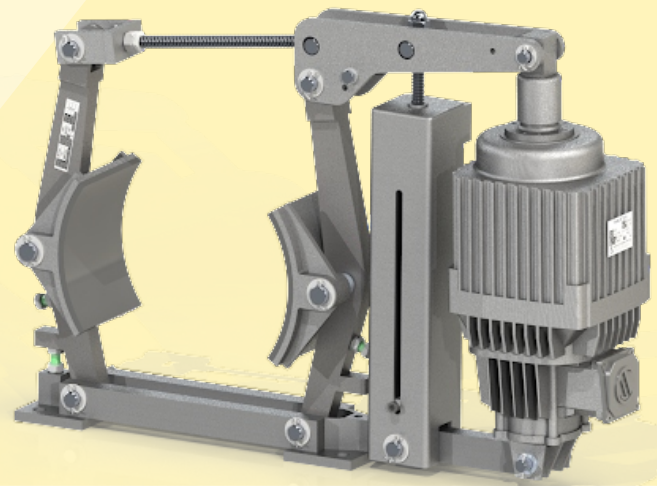

SELECTION OF BRAKE SIZE

SMD Thruster brakes are steel fabricated frames with Eldy Thruster as per din standard.

Excellent designs & good manufacturing process ensure a reliable product.

The brake torque must be \geq than motor full load as referred with drum. Formula as below:

$$T = \text{Torque in Kgm} = \frac{716 \times \text{Hp}}{\text{rpm}}$$

$$T = \text{Torque in Nm} = \frac{9552 \times \text{Kw}}{\text{rpm}}$$

Where Hp/Kw = motor output & rpm = Rev/minute

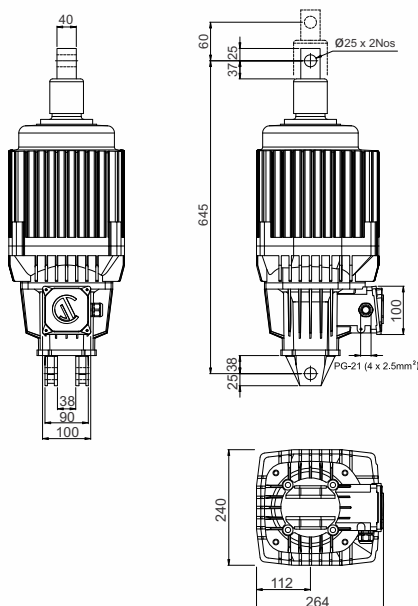

ELDY 121-6

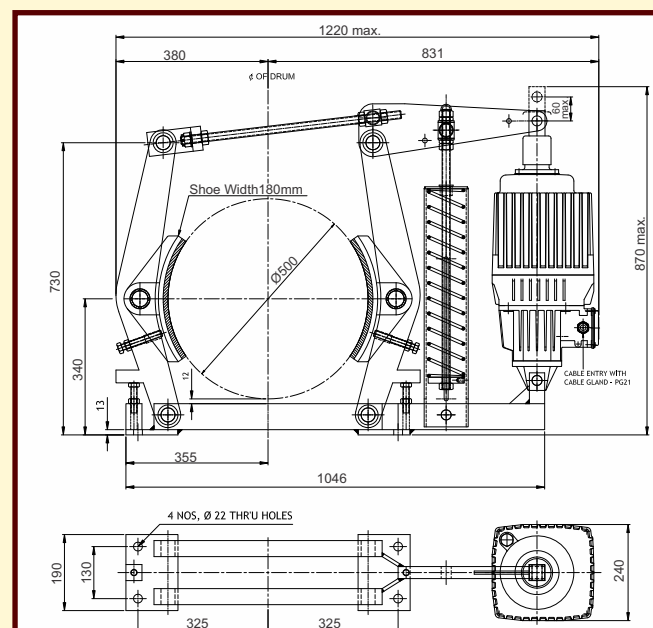

SMD-500-121/6-LAF

H. O. Unit - I : C-15/16, Nand Jyot Industrial Estate, Andheri-Kurla Road, Mumbai - 400072,
Tel : (022) 42469700/730
E-mail : sales@socgroup.in

Unit - II: Plot No. 4912, G. I. D. C., Phase IV, Vatva, Ahmedabad - 382445
Tel.: (079) 68169700/702/712
E-mail : enquiry2@socgroup.in

Visit us at :
www.speedcontrols.com
www.socremote.com

SPEED-O-CONTROLS PVT. LTD.

CRANE CONTROL GEAR V2