

# THRUSTER BRAKE ELDY SMD (600/630-301/06)



## TECHNICAL DATA

ITEM	BRAKE	THRUSTER
MODEL	SMD 600/630-301/06	ELD - 301/06
DRUM DIA	600/630 mm	-----
BRAKE SHOE FRICTION COEFFICIENT	Asbestos free / Without Rivet / BA	-----
BRAKING TORQUE	1200 - 8200 Nm	-----
THRUST	-----	300 Kg
STROKE	-----	60 mm
OIL + CAPACITY	-----	Transformer Oil IS-335 (9.8 Liters)Max
RATED VOLTAGE	-----	415 V ± 10% 50 Hz 3Ph AC
CURRENT AT 415 V AC INRUSH CURRENT	-----	2.5 Amps 12.5 Amps.(Inrush)
INSULATION	-----	F Class
INGRESS PROTECTION	-----	IP - 65 IS/IEC 60529 (2001)
AMBIENT TEMPERATURE	-----	50° C
POWER	-----	540 Watt
WEIGHT	192 Kg	33 Kg
PAINTING	Hammertone Gray Paint	
LAF	Asbestos Free Liner	
<b>OPTIONAL FEATURES</b>		
SCD	Aluminum Brake Shoe as per DIN - 15435	
LWA	Lining Wear Adjuster	
LWI	Lining Wear Indicator Limit Switch	
SS	AISA 420 Hardened & Tampered Stainless Steel Pins	
PN	Lubricators on Pins	
OL	Open Brake Limit Switch	
MS	Manual Opening & Locking System	

\* Non-Standard voltages available on enquiry

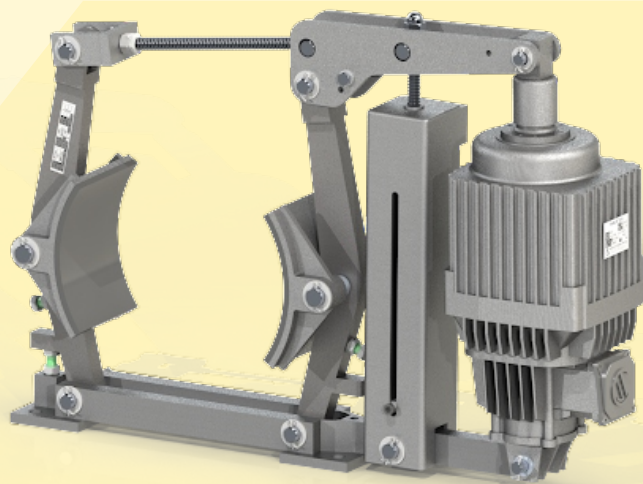

## SELECTION OF BRAKE SIZE

SMD Thruster brakes are steel fabricated frames with Eldy Thruster as per din standard.

Excellent designs & good manufacturing process ensure a reliable product.

The brake torque must be  $= >$  than motor full load as referred with drum. Formula as below:

$$T = \text{Torque in Kgm} = \frac{716 \times \text{Hp}}{\text{rpm}}$$

$$T = \text{Torque in Nm} = \frac{9552 \times \text{Kw}}{\text{rpm}}$$

Where Hp/Kw = motor output & rpm = Rev/minute

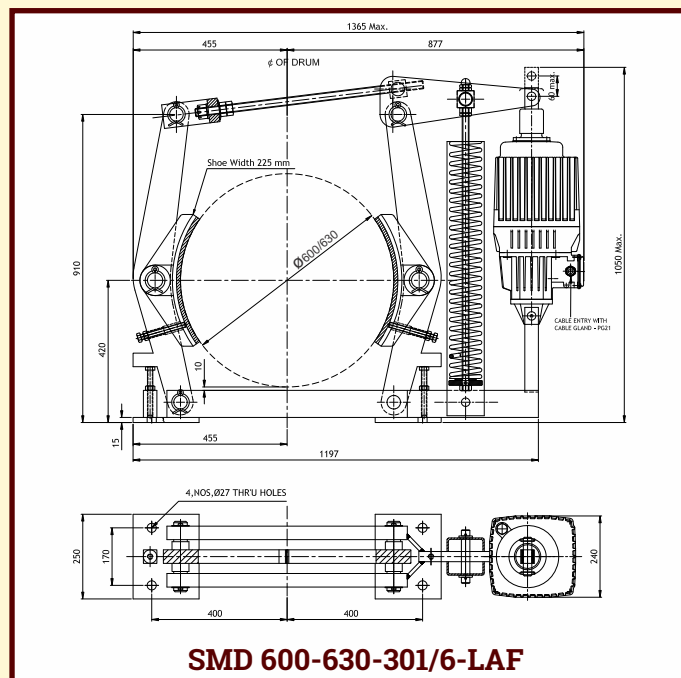
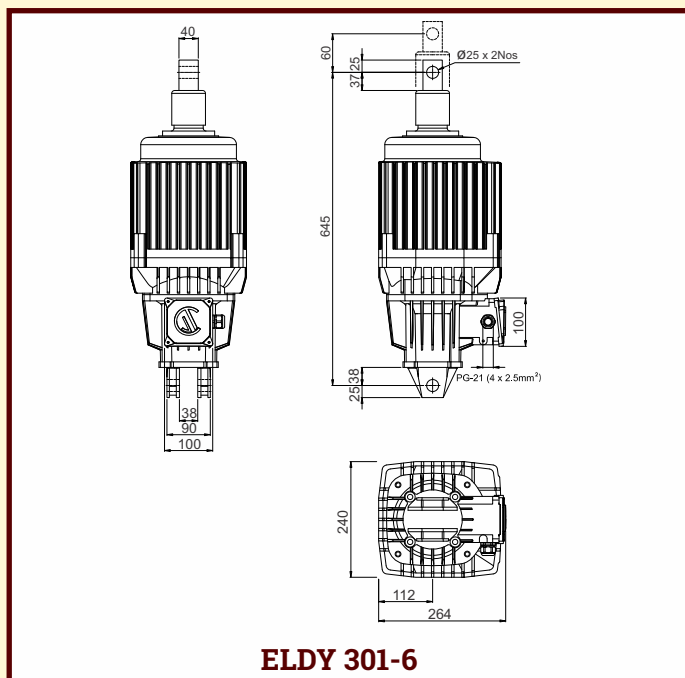

H. O. Unit - I : C-15/16, Nand Jyot Industrial Estate, Andheri-Kurla Road, Mumbai - 400072,  
Tel : (022) 42469700/730  
E-mail : sales@socgroup.in

Unit - II: Plot No. 4912, G. I. D. C., Phase IV, Vatva, Ahmedabad - 382445  
Tel.: (079) 68169700/702/712  
E-mail : enquiry2@socgroup.in

Visit us at :  
www.speedcontrols.com  
www.socremote.com

**SPEED-O-CONTROLS PVT. LTD.**  
**CRANE CONTROL GEAR V2**